

# SUN2000-12/15/17/20/25KTL-M5 Smart PV Controller



## Active Safety

AI Powered Arcing Protection



## Higher Yields

Up to 30% More Energy with Optimizer



## Flexible Communication

WLAN, Fast Ethernet, 4G  
Communication Supported

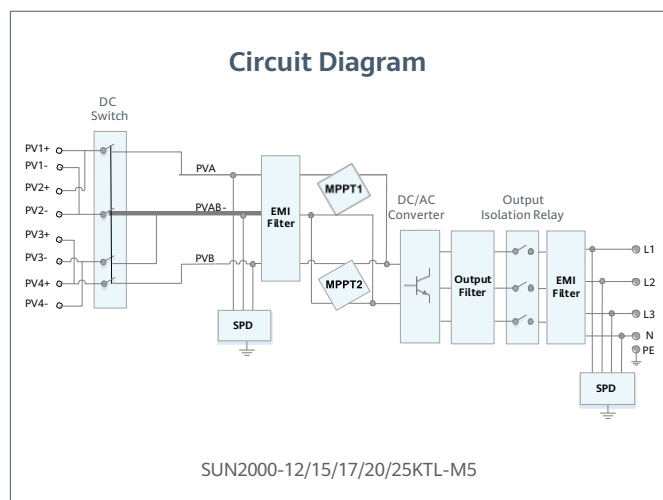
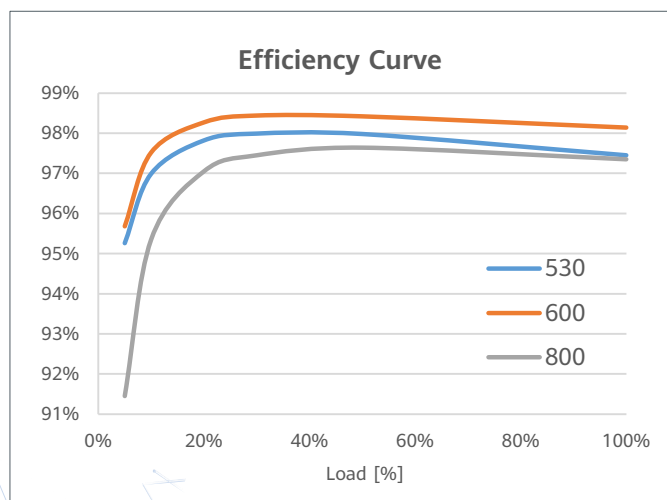

# SUN2000-12/15/17/20/25KTL-M5 Technical Specification

Technical Specification	SUN2000-12KTL-M5	SUN2000-15KTL-M5	SUN2000-17KTL-M5	SUN2000-20KTL-M5	SUN2000-25KTL-M5
-------------------------	------------------	------------------	------------------	------------------	------------------

## Efficiency

Max. efficiency	98.4%	98.4%	98.4%	98.4%	98.4%
European weighted efficiency	97.9%	98.0%	98.1%	98.1%	98.2%

## Input

Recommended max. PV power <sup>1</sup>	18,000 Wp	22,500 Wp	25,500 Wp	30,000 Wp	37,500 Wp
Max. input voltage <sup>2</sup>	1100 V				
Full-load MPPT voltage range	370V~800V	410V~800V	440V~800V	480V~800V	530~800V
MPPT Operating voltage range <sup>3</sup>	200 V ~ 1000 V				
Start-up voltage	200 V				
Rated input voltage	600 V				
Max. input current per MPPT	30 A (two string) / 20 A (single string)				
Max. short-circuit current	40 A				
Number of MPP trackers	2				
Max. number of inputs	4				

## Output

Grid connection	Three phase				
Rated output power	12,000 W	15,000 W	17,000 W	20,000 W	25,000 W
Max. apparent power	13,200 W	16,500 VA	18,700 VA	22,000 VA	27,500 VA
Rated output voltage	380 Vac, 400 Vac, 415Vac, 3W + N + PE				
Rated AC grid frequency	50 Hz / 60 Hz				
Max. output current	18.2A/380Vac 17.3A/400Vac 16.7A/415Vac	25.2A/380Vac 23.9A/400Vac 23.1A/415Vac	28.6A/380Vac 27.1A/400Vac 26.1A/415Vac	33.6A/380Vac 31.9A/400Vac 30.8A/415Vac	42.0A/380Vac 39.9A/400Vac 38.5A/415Vac
Adjustable power factor	0.8 leading ... 0.8 lagging				
Max. total harmonic distortion	≤ 3 %				

## Features & Protections

Overvoltage Category	PV II/AC III
Input-side disconnection device	Yes
Anti-islanding protection	Yes
AC over-current protection	Yes
DC reverse-polarity protection	Yes
String fault detection	Yes
DC surge protection	TYPE II
AC surge protection	CLASS II
Residual current monitoring unit	Yes
Arc fault protection	Yes
Ripple control	Yes
Integrated PID recovery <sup>4</sup>	Yes

## General Data

Operation temperature range	-25 ~ + 60 °C (-13 °F ~ 140 °F)
Relative humidity	0 % RH ~ 100% RH
Max. operating altitude	0 ~ 4,000 m (13,123 ft.) (Derating above 2000 m)
Cooling	Smart air cooling
Display	LED Indicators; Integrated WLAN + FusionSolar App
Communication	RS485; WLAN/Ethernet via Smart Dongle-WLAN-FE (Optional) 4G / 3G / 2G via Smart Dongle-4G (Optional)
Weight (with mounting plate)	21kg (46.4 lb)
Dimensions (W x H x D) (incl. mounting plate)	546 x 460 x 228mm (21.5 x 18.1 x 9.0 inch)
Degree of protection	IP66

## Optimizer Compatibility

DC MBUS compatible optimizer	SUN2000-450W-P, SUN2000-450W-P2, SUN2000-600W-P, MERC-1300W-P, MERC-1100W-P
------------------------------	---

## Standard Compliance (more available upon request)

Safety	EN/IEC 62109-1, EN/IEC 62109-2
Grid connection standards	G99, EN 50549, CEI 0-21, CEI 0-16, VDE-AR-N-4105, VDE-AR-N-4110, C10/11, ABNT, VFR 2019, UNE 217001, UNE 217002, RD 244, TOR D4, IEC61727, IEC62116

<sup>\*1</sup> Inverter max input PV power is 40,000 Wp when long strings are designed and fully connected with SUN2000-450W-P power optimizers.

<sup>\*2</sup> The maximum input voltage is the upper limit of the DC voltage. Any higher input DC voltage would probably damage inverter.

<sup>\*3</sup> Any DC input voltage beyond the operating voltage range may result in inverter improper operating.

<sup>\*4</sup> SUN2000-12~20KTL-M2 raises potential between PV- and ground to above zero through integrated PID recovery function to recover module degradation from PID. Supported module types include: P-type (mono, poly)